



Windsor Arbor

Model# 11112

Assembly Instructions

Part #	Description	Box#	Qty
1	4" sq. x 84" Left Post	1	2
2	4" sq. x 84" Right Post	1	2
3	2" sq. x 29 $\frac{3}{4}$ " Top/Bottom Cross Rail	2	4
4	2" sq. x 29 $\frac{3}{4}$ " Center Cross Rail	2	8
5	$\frac{7}{8}$ x 1 $\frac{1}{2}$ x 59 $\frac{1}{2}$ " Vertical Rail	1	6
6	1 $\frac{1}{2}$ x 4 x 72" Arbor Top Rail	1	2
7	$\frac{7}{8}$ x 1 $\frac{1}{2}$ x 72" Arbor Top Overhead Rail	1	2
8	2" sq. x 26 $\frac{3}{4}$ " Arbor Top Cross Rail	1	1
8	2" sq. x 26 $\frac{3}{4}$ " Arbor Top Cross Rail	2	4
9	4" sq. Flat Post Cap	1	4
10	24" Steel Ground Anchor (U-shaped)	1	4
11	Hardware Bag (includes:)	1	1
	4" End Cap		4
	$\frac{7}{8}$ x 1 $\frac{1}{2}$ " End Cap		4
	1 $\frac{1}{4}$ " Painted Screw		26
	#8 - 1" Painted Self Tapping		8
	Super Glue Tube		1

General Information

PLEASE READ THROUGH BEFORE BEGINNING ASSEMBLY.

IMPORTANT: Check boxes for Contents Listed

Check inside of parts as some parts are packaged inside of others

In the event of missing, damaged or defective parts please call our customer service dept. at 1-877-258-6020

When assembling components, place on a clean, flat non-abrasive surface to avoid scratches

Tools Required

- ... Battery or Electric Drill with #2 phillips bit
- ... Tape Measure
- ... Hammer or Rubber Mallet (recommended)
- ... Shovel or Post Hole Digger (recommended)

Warranty Statement

20 Year Guarantee

Please call manufacturer direct with questions concerning missing or defective parts at Toll Free: 877-258-6020.

Dura-trel, Inc. products are warranted to be free from manufacturing defects resulting in delaminating, peeling, flaking, corroding, cracking, crazing, or extreme amounts of fading or bleaching causing the PVC to change to its natural color for a period of 20 years from the date of purchase.

Normal weathering is defined as exposure to sunlight and extremes of weather and atmosphere which will cause any colored surface to gradually fade.

CONDITIONS NOT COVERED BY THIS WARRANTY:

- A. Physical abuse, misuse, neglect, or improper storage.
- B. Improper installation or installation not in strict adherence to the instructions written by Dura-Trel, Inc.
- C. This warranty does not apply if materials are painted, varnished, or coated with any substance.
- D. Dura-Trel, Inc. is not responsible for damages to product during shipping.
- E. Damage attributable to atmospheric pollutants, hail, lightning, hurricane, tornado, wind borne objects, earthquake, fire, mildew, casualty, act of God, building or ground settlement, or subjection to stress or weight.

CLAIMS AND REMEDIES:

If a Dura-Trel, Inc. product is determined to have a manufacturing defect which is covered by this warranty, Dura-Trel, Inc. will replace the material containing the defect (labor no included) F.O.B from the point of manufacture. Dura-trel, Inc. will not be responsible for any cost incurred in the removal or reinstallation of the product.

Important: An claims must be sent to the following address and should describe the defect claim.

Dura-Trel, Inc., P.O. Box 122, Sheboygan Falls, WI 53085

Dura-Trel, Inc. reserves the right to discontinue or change its design, and or color. If the original color or style is not available, Dura-Trel, Inc. shall have the right to substitute a product designated by Dura-Trel, Inc.

Dura-Trel, Inc. shall not be liable for any incidental, special, or consequential damages arising out of the use of these products

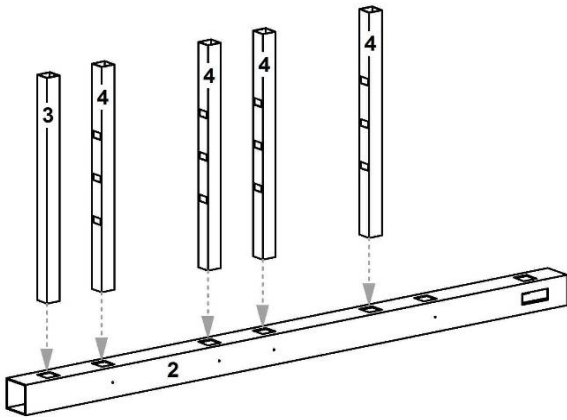

1

Lay out one right post (part 2). Starting at bottom, insert one top/bottom rail (part 3) and four center rails (part 4).

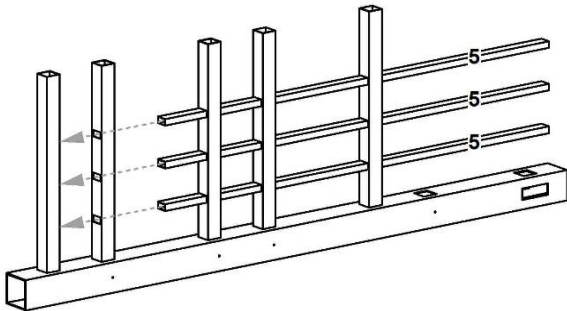

2

Slide three vertical rails (part 5) through center rails and into top/bottom rail.

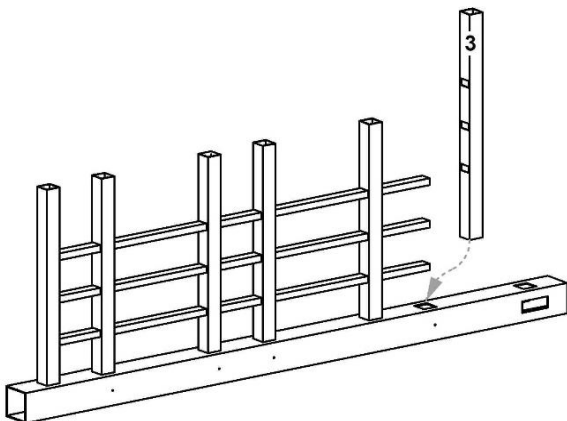

3

Insert one top/bottom rail (part 3) into right post, sliding three vertical rails into top/bottom rail.

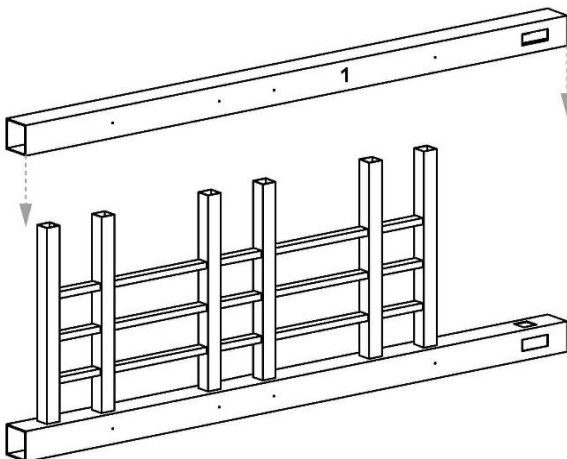

4

Slide left post (part 1) over corresponding top/bottom and center rails. **DO NOT** screw arbor panel together.

REPEAT steps 1-4 for the second arbor panel.

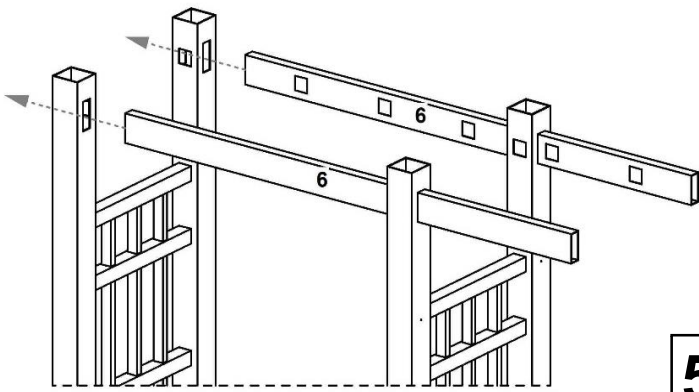

5

With arbor panels lying down and screw pilot holes of each arbor panel facing out, slide two arbor top rails (part 6) all the way through both routed holes at the top of each arbor panel.

Note: 2" sq. holes should line up with 2" sq. holes in the top of the arbor panels. This will leave 7" of overhang on each side of the arbor.

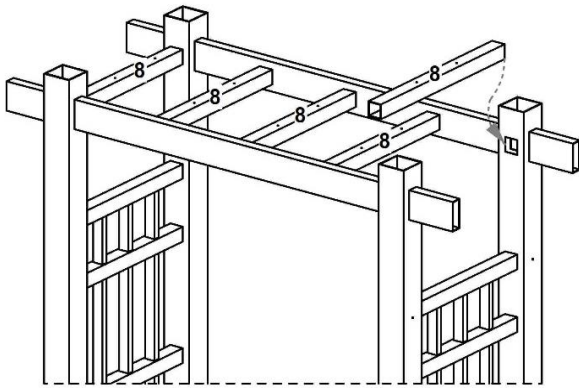

6

Insert five arbor top cross rails (part 8) into arbor top rails and arbor panel posts by carefully separating posts just enough to insert the five rails. When inserting rails, insert with screw pilot holes facing up.

Note: Outer two arbor top cross rails are inserted into posts, and then lock into the arbor top rail.

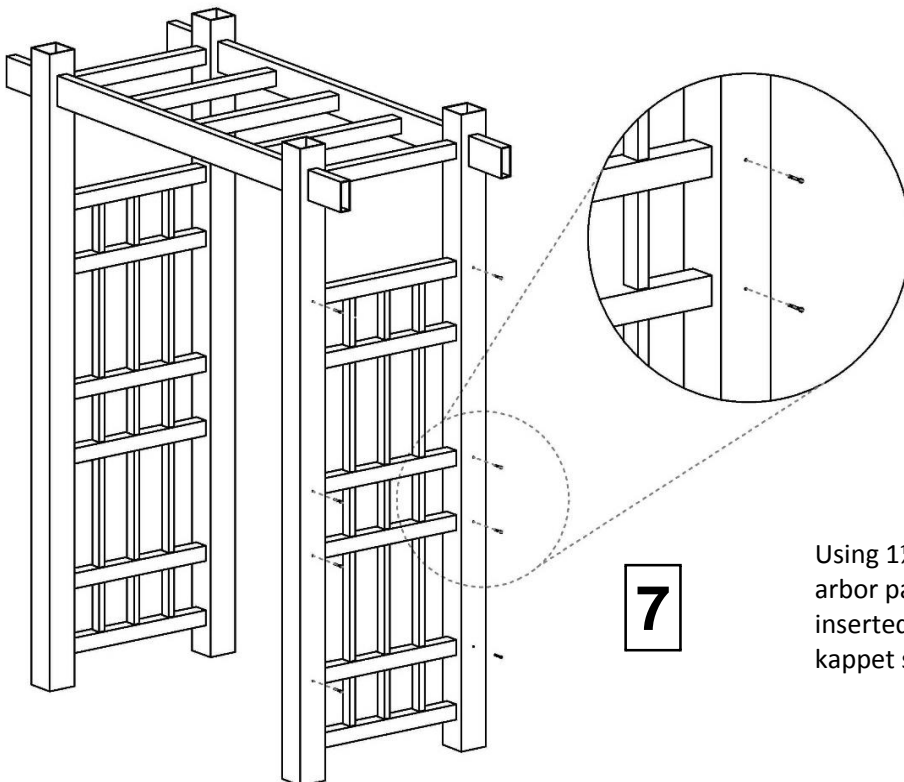

7

Using 1½" kappet screws, screw together both arbor panels. Be sure that all parts are fully inserted into posts before securing. Snap kappet screw caps over screw heads.

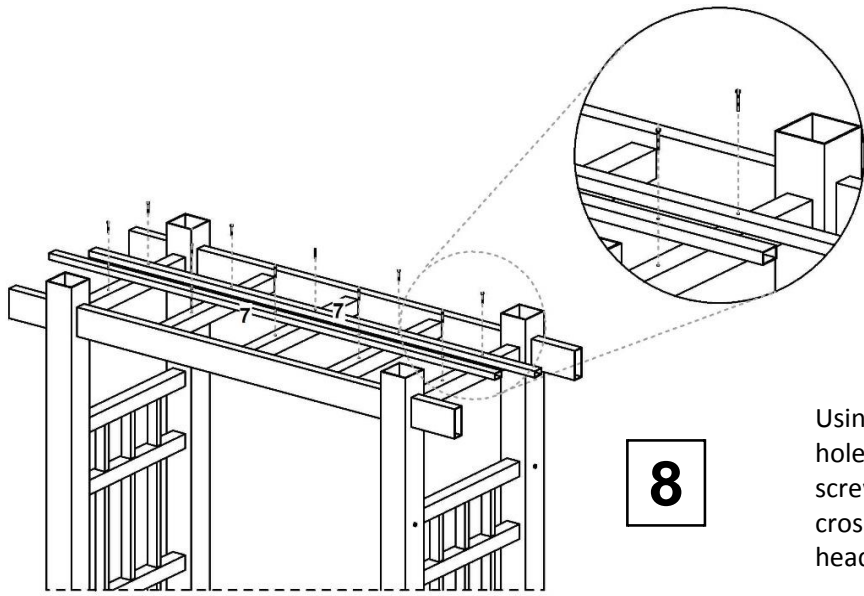

8

Using 1½" kappet screws, insert screws through holes of two overhead rails (part 7). Fasten screws to screw pilot holes of the five arbor top cross rails. Snap kappet screw caps over screw heads.

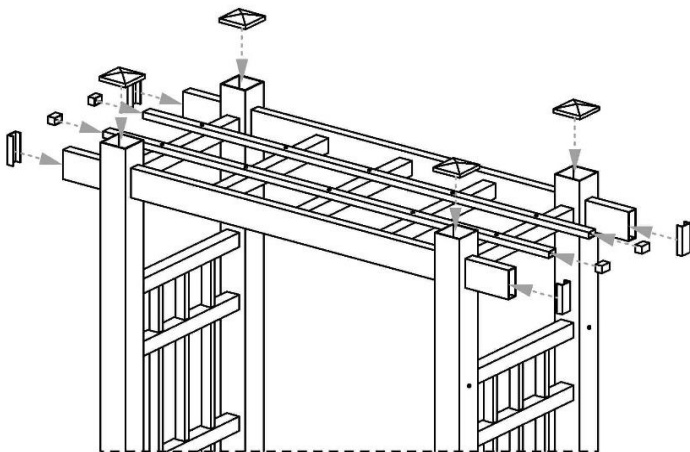

9

Apply PVC glue to inner edges of the four flat post caps (part 9) and place on top of each post. Glue four 4" arbor top end caps onto ends of each arbor top rail. Glue four overhead rail end caps onto ends of each overhead rail.

ARBOR INSTALLATION

Option 1

Slide one 24" steel u-channel ground anchor (part 10) into bottom of each post. Slide ground anchor until it meets bottom cross rail. Using 1" self-tapping white-head screw fasten post to ground anchor.

Using ground anchor installation layout drawing, dig holes approximately 16" deep. Set arbor in holes and level. Back fill with soil removed from holes. For permanent installation fill with cement.

Option 2

Using ground anchor installation layout drawing, pound ground anchors into ground according to dimensions. When pounding into ground, use block of wood to prevent ground anchor from bending.

Slide arbor over ground anchors. Using 1" self-tapping white-head screw fasten post to ground anchor.

Option 3

Using ground anchor installation layout drawing, dig holes 16" deep according to dimensions. Fill with cement and place ground anchors in wet cement. Be sure that ground anchors are straight and in accordance with dimension of ground anchor installation layout drawing. Allow cement to dry. NOTE: There is very little room for error with this installation method.

Slide arbor over ground anchors. Using 1" self-tapping white-head screw fasten post to ground anchor.

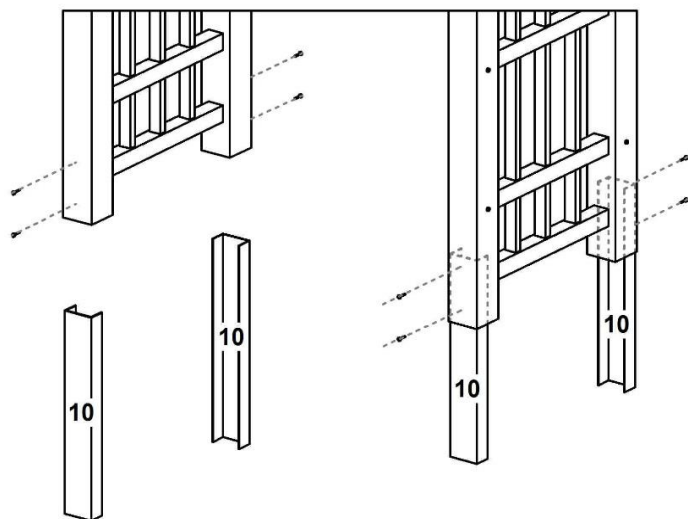

**Ground Anchor
Installation Layout**

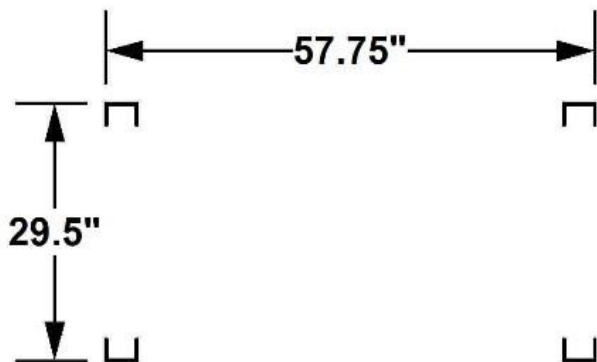

11112	Windsor Arbor	
1	4" sq. x 84" WDA Left Post	2.00
2	4" sq. x 84" WDA Right Post	2.00
3	2" sq. x 29¾ WD Top/Bottom R	4.00
4	2" sq. x 29¾ WD Center Rail	8.00
5	¾ x 1½ x 59½" Rail - Thin	6.00
6	1½ x 4 x 72" WDA Arbor Top	2.00
7	¾ x 1½ x 72" WDA Overhead R	2.00
8	2" sq. x 26¾ CYA Top Cross R	5.00
9	24" Steel Grnd Anch (U-shaped)	4.00
10	4" sq." Flat Cap	4.00
11	Hardware Bag	1.00
	¾ x 1½" End Cap	4.00
	1¼" Painted Screw	26.00
	#8 - 1" Self Tapping White He	8.00
	PVC Glue	1.00